



User Manual

Replus 3600MTLB-US Replus 4200MTLB-US

Replus 5000MTLB-US



U.S.A
Add: 301 Howard St, Suite 850, San Francisco, CA 94105.
T: +1 415 852 7418
E: america@renesola.com

Australia
Add: 18 Corporate Blvd. Bayswater, VIC 3153, Australia
T: +61 481 251 275
E: australia@renesola.com

Europe
Add: Renesola Deutschland GmbH, Lyoner Strasse 15, 60529 Frankfurt/M, Germany
T: +49 69 663 786 9-0
E: europa@renesola.com

APMEA&China
Add: F-15, Manpo Intl. No.500 WestYan'an Rd, Shanghai, China 200050
T: +86 21 62809180
E: apmea@renesola.com

Web: www.renesola.com
E: stringinverter@renesola.com

Contents

1 Notes on this manual

- 1.1 Validity
- 1.2 Target Group
- 1.3 Additional information
- 1.4 Storage of the manuals
- 1.5 Symbols Used
- 1.6 Markings on this product

2 Safety and conformity

- 2.1 Safety Instructions

3 Product Description

- 3.1 Inverter Overview:
- 3.2 Information of Label
- 3.3 Dimensions and weight
- 3.4 Transportation
- 3.5 Storage of Inverter
- 3.6 The advantage of the unit

4 Unpacking

- 4.1 Unpacking and inspection

5 Installation and Electrical Connection

- 5.1 Safety
- 5.2 Selecting the installation location
- 5.3 Mounting the Inverter with bracket
- 5.4 Fixed the inverter on the wall
- 5.5 Check Inverter Installation Status
- 5.6 Electrical Connection
- 5.7 Commissioning Checking

6 LCD display

- 6.1 Display and messages
- 6.2 Setting the LCD display

7 Communications

- 7.1 Monitoring Products
- 7.2 Monitoring System
- 7.3 RS485 cable connection
- 7.4 Using shine tool to set the information of the inverter

8 Start-Up and shut down the inverter

- 8.1 Start-Up the inverter
- 8.2 Disconnecting the Inverter

9 Maintenance and Cleaning

- 9.1 Checking Heat Dissipation
- 9.2 Cleaning the Inverter
- 9.3 Checking the DC switch

10 Decommissioning

- 10.1 Dismantling the Inverter
- 10.2 Packing the Inverter
- 10.3 Storing the Inverter
- 10.4 Disposing of the Inverter

11 Trouble shooting

12 Operation Modes

- 12.1 Normal Mode
- 12.2 Fault Mode
- 12.2 Shutdown Mode

13 De-rating Operation

14 Manufacturer Warranty

15 Technical Data

- 15.1 Specification
- 15.2 Efficiency curve

16 Download Address

17 Contact

1 Notes on this manual

1.1 Validity

This manual describes the assembly, installation, commissioning and maintenance of the following Replus Inverters :

Replus 3600MTLB-US

Replus 4200MTLB-US

Replus 5000MTLB-US

This manual does not cover any details concerning equipment connected to the Replus inverter (e.g. PV modules). Information concerning the connected equipment is available from the manufacturer of the equipment.

1.2 Target Group

 CAUTION	This manual is for qualified personnel. Qualified personnel have received training and have demonstrated skills and knowledge in the construction and operation of this device. Qualified personnel are trained to deal with the dangers and hazards involved in installing electric devices.
---	---

1.3 Additional information

Find further information on special topics in the download area at www.Renesola.com

1.4 Storage of the manuals

The manual and other documents must be stored in a convenient place and be available at all times. We assume no liability for any damage caused by failure to observe these instructions.

1.5 Symbols Used

The following types of safety instructions and general information appear in this document as described below:



Read the manual!



Danger indicates a hazardous situation which, if not avoided, will result in death or serious injury.



WARNING indicates a hazardous situation which, if not avoided, could result in death or serious injury.











CAUTION indicates a hazardous situation which, if not avoided, could result in minor moderate injury.



Failure to observe a warning indicated in this manual may lead to damage to property

1.6 Markings on this product

Symbol	description
	Warning regarding dangerous voltage The product works with high voltage. All work on the product must only be performed as described in its documentation.
	Beware of hot surface The product can become hot during operation. Do not touch the product during operation.
	Observe the operating instructions Read the product's documentation before working on it. Follow all safety precautions and instructions as described in the documentation.
	FCC certificate
	Intertek ETL semko mark it apply to the Replus MTLB™ US series certify that the inverter meet the safety standard UL1741.
	Point of connection for grounding protection.
	Direct Current (DC)
	Alternating Current (AC)

2.1 Safety Instructions



Danger to life due to lethal voltages!

Lethal voltages are present within the unit and on the power supply lines. Therefore, only authorized electricians may install and open the unit.



DANGER

Even when the unit is disconnected, high contact voltages may still be present within the unit.



Danger of burn injuries due to hot enclosure parts!

During operation, the four sides of the enclosure lid and the heat sink may become hot.



DANGER

Only touch the front enclosure lid during operation.

Possible damage to health as a result of the effects of radiation!



In special cases, there may still be interference for the specified application area despite maintaining standardized emission limit values (e.g. when sensitive equipment is located at the setup location or when the setup location is near radio or television receivers). In this case, the operator is obliged to take proper action to rectify the situation.



CAUTION

Do not stay closer than 20 cm to the inverter for any length of time.

Grounding the PV generator

Comply with the local requirements for grounding the PV modules and the PV generator. Growatt recommends connecting the generator frame and other electrically conductive surfaces in a manner which ensures continuous conduction with ground these in order to have optimal protection of the system and personnel.



NOTICE



The inverter may only be operated with a permanent connection to the public power grid. The inverter is not intended for mobile use. Any other or additional use is not considered the intended use. The manufacturer/supplier is not liable for damage caused by such unintended use. Damage caused by such unintended use is at the sole risk of the operator

Capacitive Discharge Currents

PV modules with large capacities relative to earth, such as thin-film PV modules with cells on a metallic substrate, may only be used if their coupling capacity does not exceed 470nF. During feed-in operation, a leakage current flows from the cells to earth, the size of which depends on the manner in which the PV modules are installed (e.g. foil on metal roof) and on the weather (rain, snow). This "normal" leakage current may not exceed 50mA due to the fact that the inverter would otherwise automatically disconnect from the electricity grid as a protective measure.



◆ Certified countries

With the appropriate settings, the unit will comply with the requirements specified in the following standards and directives

- > UL 1741
- > IEEE 1547
- > CSA C22.2 No.107.1-1
- > FCC Part15

Replus can preset special grid parameters for other countries installation locations according to customer requests after evaluation by Renesola. You can make later modifications yourself by changing software parameters with respective communication products (e.g. Replusbus or ReplusNet ect). To change the grid-relevant parameters, you need a personal access code, if you need it ,please contact with Renesola.

◆ DC and AC Switch

Separate the Replus MTLB-US securely from the grid and the PV generators using DC and AC Switch. DC and AC Switch shall be able to disconnect all unground conductors after installation.

◆ Grounding the PV modules

The Replus MTLB-US is a transformerless inverter. That is why it has no galvanic separation. Do not ground the DC circuits of the PV modules connected to the Replus MTLB-US. Only ground the mounting frame of the PV modules. If you connect grounded PV modules to the Replus MTLB-US, the error message "PV ISO Low".

◆ Appropriate

The Replus Inverter converts DC Current from PV generator into AC current. The inverter is suitable for mounting indoors and outdoors. You can use the AC current generated as follows:

House grid:	Energy flows into the house grid. The consumers connected, for example, household devices or lighting, consume the energy. The energy left over is fed into the public grid. When the Replus is not generating any energy, e.g., at night, the consumers which are connected are supplied by the public grid. The Replus does not have its own energy meter. When energy is fed into the public grid, the energy meter spins backwards.
Public grid:	Energy is fed directly into the public grid. The Replus is connected to a separate energy meter. The energy produced is compensated at a rate depending on the electric power company.

Persons with limited physical or mental abilities may only work with the Replus inverter following proper instruction and under constant supervision. Children are forbidden to play with the Replus inverter. Must keep the Replus inverter away from children

◆ Qualification of Skilled Workers

- Knowledge of how an inverter works and is operated
- Instruction in how to deal with the dangers and risks associated with installing and using electrical devices and plants
- Training in the installation and commissioning of electrical devices and plants
- Knowledge of all applicable standards and guidelines
- Knowledge and observance of this manual and all safety instructions

3 Product Description

3.1 Inverter Overview:

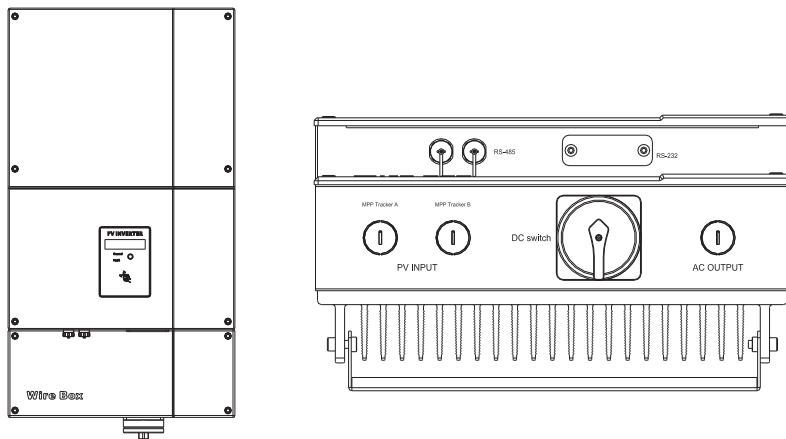

3.2 Information of Label

You can identify the pv inverter by the type label. It is on the left side of the enclosure.

- The type of product (Type/Model)
- Device-specific characteristics
- Specifications of the inverter
- Serial number

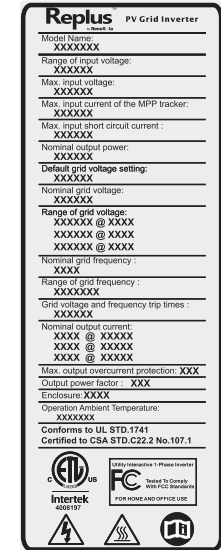

3.3 Dimensions and weight

Model	Height (H)	Width (W)	Depth (D)	Weight
Replus 3600MTLB-US	650 mm 25.6 inch	360 mm 14.2 inch	188 mm 7.4 inch	24 kg 52.9 lb
Replus 4200MTLB-US	650 mm 25.6 inch	360 mm 14.2 inch	188 mm 7.4 inch	26 kg 57.3 lb
Replus 5000MTLB-US	650 mm 25.6 inch	360 mm 14.2 inch	188 mm 7.4 inch	26 kg 57.3 lb

3.4 Transportation

The inverter is thoroughly tested and inspected strictly before delivery. Our inverters leave our factory in proper electrical and mechanical condition. Special packaging ensures safe and careful transportation. However, transport damage may still occur. The shipping company is responsible in such cases. Thoroughly inspect the inverter upon delivery. Immediately notify the responsible shipping company if you discover any damage to the packaging which indicates that the inverter may have been damaged or if you discover any visible damage to the inverter. We will be glad to assist you, if required. When transporting the inverter, the original or equivalent packaging should be used, and the maximum layers for original carton is four, as this ensures safe transport.

3.5 Storage of Inverter

If you want to storage the inverter in your warehouse, you should choose an appropriate location to store the inverter.

- The unit must be stored in original package and desiccant must be left in the package.
- The storage temperature should be always between -25°C and +60°C. And the storage relative humidity should be always between 0 and 95%.
- If there are a batch of inverters need to be stored, the maximum layers for original carton is four.
- After long term storage, local installer or service department of ReneSola should perform a comprehensive test before installation

3.6 The advantage of the unit

- Maximum efficiency of 98%
- CEC efficiency of 97.0%
- Wide input voltage range from 100-600V
- Integrated wire box
- Integrated DC switch
- Multi MPP controller
- Adapt to multi grid model(208Vac/240Vac/277Vac)
- Sound control
- Easy installation

4.1 Unpacking and inspection

Thoroughly inspect the packaging upon received. If any damage to the carton is visible, or if you find that the inverter unit is damaged after unpacking, please notify the shipping company and ReneSola Ltd immediately.

Meanwhile please check the delivery for completeness and for visible external damages of the inverter. If there are anything damaged or missing, please contact your dealer. Don't dispose its original package. If you want to transport the inverter, it is better to store the inverter into the original package.

Complete delivery should contain as follows:

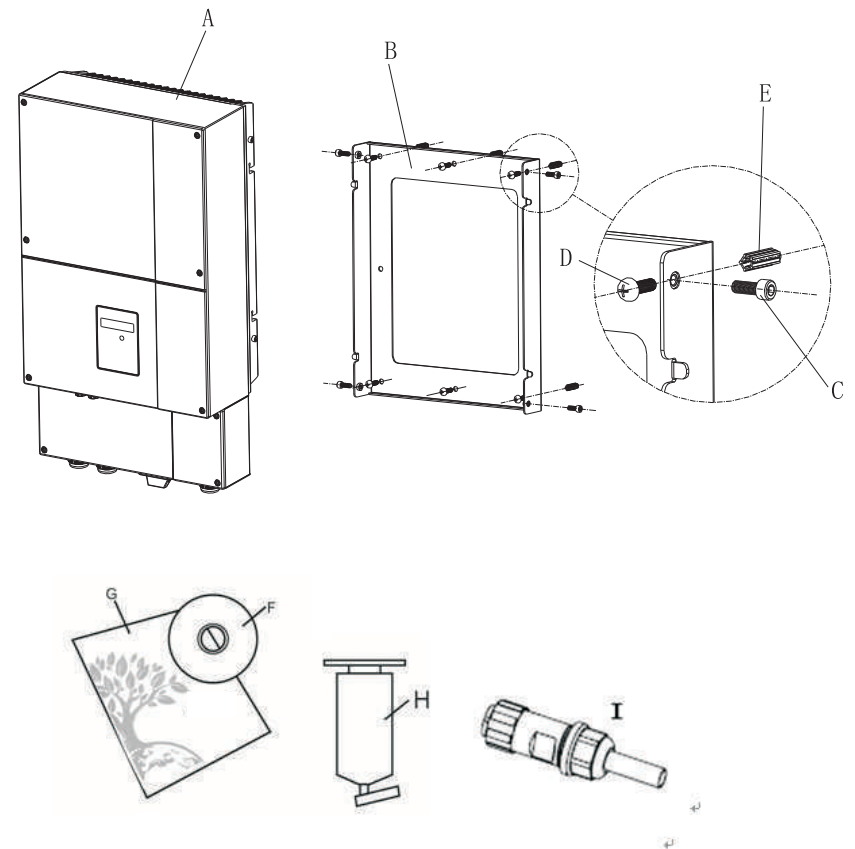

Installation and Electrical Connection 5

Item	Name	Quantity
A	inverter	1
B	Mounting frame	1
C	Safety-lock screws	4
D	Mounting screws	8 (for Replus 4200MTLB-US& Replus 5000MTLB-US 6 (for Replus 3600MTLB-US)
E	Mounting frame screws sleeve	8 (for Replus 4200MTLB-US& Replus 5000MTLB-US 6 (for Replus 3600MTLB-US)
F	Monitor software(disk)	1(Optional)
G	Manual	1
H	Bluetooth	1(Optional)
I	Rs485 connectors	2

 NOTICE	<p>Though the packaging box of Replus is durable, please treat the packing box gently and avoid dispose the packing box. In this package, they are inverter ,cystosepiment and carton from inside to outside.</p>
---	---

5.1 Safety



Danger to life due to fire or explosion
Despite careful construction, electrical devices can cause fires.
Do not install the inverter on easily flammable materials and where flammable materials are stored.



Risk of burns due to hot enclosure parts
Mount the inverter in such a way that it cannot be touched inadvertently.

- All electrical installations shall be done in accordance with the local and national electrical codes. Do not remove the casing. Inverter contains no user serviceable parts. Refer servicing to qualified service personnel. all wiring and electrical installation should be conducted by a qualified service personnel .
- Carefully remove the unit from its packaging and inspect for external damage. If you find any imperfections, please contact your local dealer.
- Be sure that the inverters connect to the ground in order to protect property and personal safety.
- The inverter must only be operated with PV generator. Do not connect any other source of energy to it.
- Both AC and DC voltage sources are terminated inside the PV Inverter. Please disconnect these circuits before servicing.
- This unit is designed to feed power to the public power grid (utility) only. Do not connect this unit to an AC source or generator. Connecting Inverter to external devices could result in serious damage to your equipment.
- When a photovoltaic panel is exposed to light, it generates a DC voltage. When connected to this equipment, a photovoltaic panel will charge the DC link capacitors.
- Energy stored in this equipment's DC link capacitors presents a risk of electric shock. Even after the unit is disconnected from the grid and photovoltaic panels, high voltages may still exist inside the PV-Inverter. Do not remove the casing until at least 5 minutes after disconnecting all power sources.
- Although designed to meet all safety requirements, some parts and surfaces of Inverter are still hot during operation. To reduce the risk of injury, do not touch the heat sink at the back of the PV-Inverter or nearby surfaces while Inverter is operating.



5.2 Selecting the installation location

- This is guidance for installer to choose a suitable installation location, to avoid potential damages to device and operators.
- Raintight or wet location hubs that comply with the requirements in the Standard for Conduit, Tubing, and Cable Fittings, UL 514B, are to be used.
- The unit shall be mounted at least 914 mm (3 feet) above the ground.
- The installation location must be suitable for the inverter's weight and dimensions for a long period time.
- Select the installation location so that the status display can be easily viewed.
- Do not install the inverter on structures constructed of flammable or thermolabile materials.
- The humidity of the installation location should be 0~95% without condensation.
- The installation location must be freely and safely to get at all times.
- Vertically installation or tilted backwards by max. 15°. and make sure the connection of inverter must be downwards. Never install horizontal and avoids forward and sideways tilt.
- Be sure that the inverter is out of the children's reach.
- Don't put any things on the inverter. Do not cover the inverter.
- Do not install the inverter near television antenna or any other antennas, antenna cables.
- Inverter requires adequate cooling space. Providing better ventilation for the inverter to ensure the heat escape adequately. The ambient temperature should be below 40°C to ensure optimum operation. Please make sure the inverter is installed at the right place, The inverter can't install close to trunk.

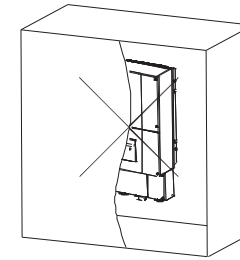
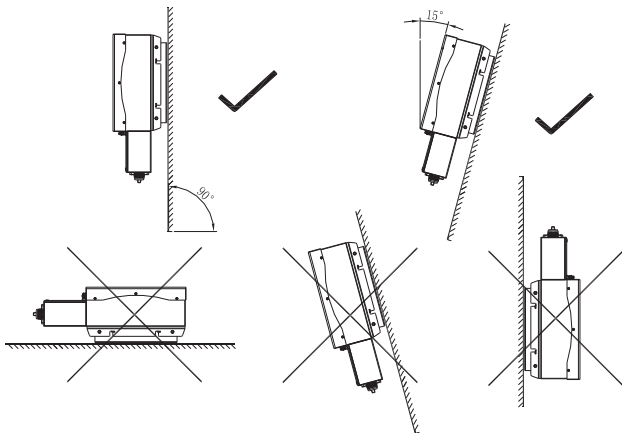

The inverter can't install to direct sunlight, drench, fire location. We suggest that the inverters should be installed at the location with some cover or protection.

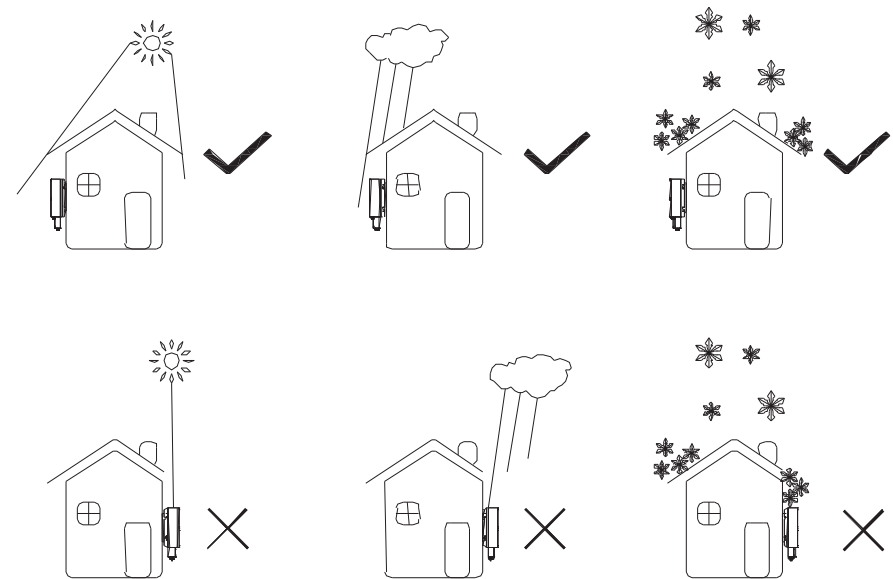

- Observe the minimum clearances to walls, other inverters or objects as shown in the diagram below in order to guarantee sufficient heat dissipation.

Direction	Min.clearance(cm)
above	30
below	50
sides	30
front	30

Ambient dimensions of one inverter

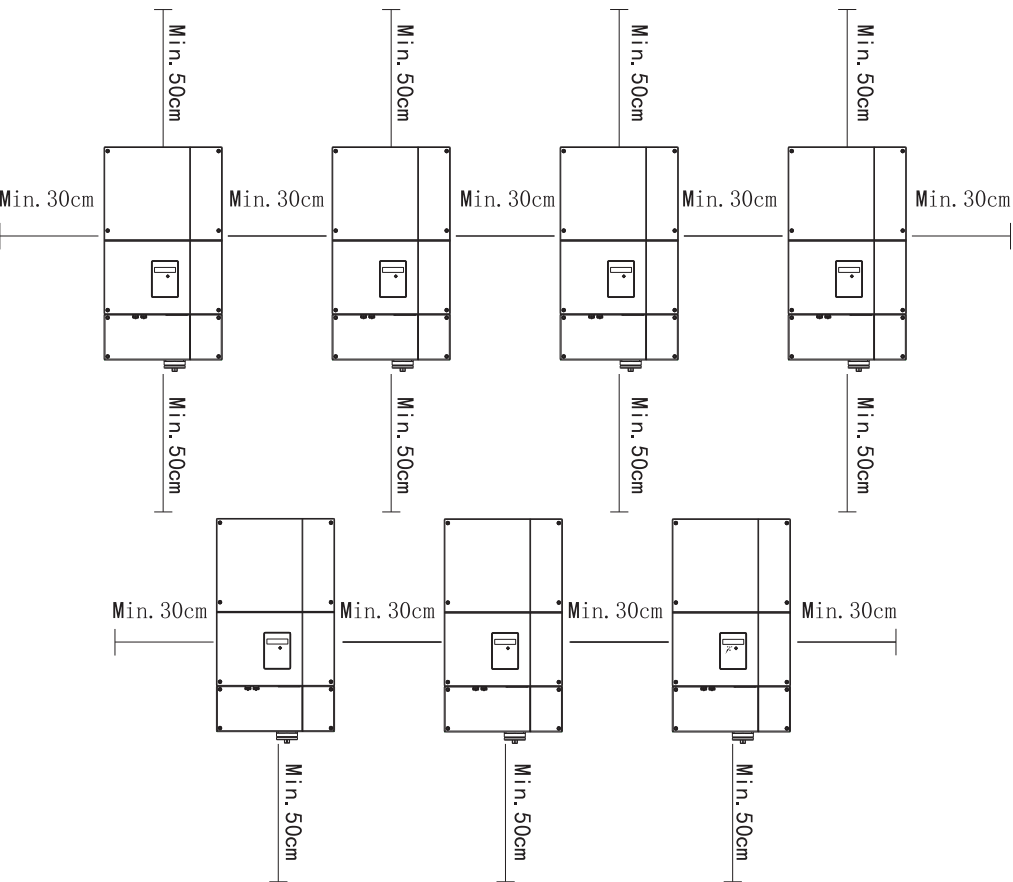
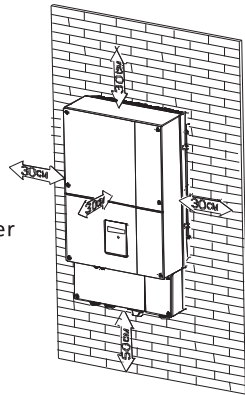

Ambient dimensions of a series inverters

- There must be sufficient clearance between the individual inverters to ensure that the cooling air of the adjacent inverter is not taken in.
- If necessary, increase the clearance spaces and make sure there is enough fresh air supply to ensure sufficient cooling of the inverters.

5.3 Mounting the Inverter with bracket



In order to avoid electrical shock or other injury, inspect existing electronic or plumbing installations before drilling holes.

- The dimension of bracket as follow

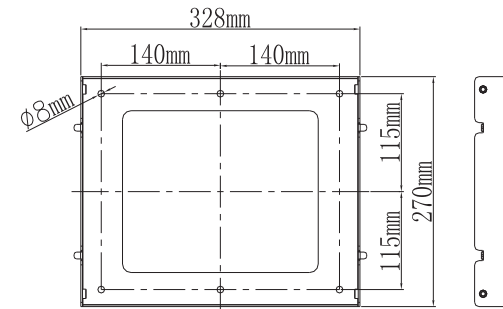

For Replus 3600MTLB-US

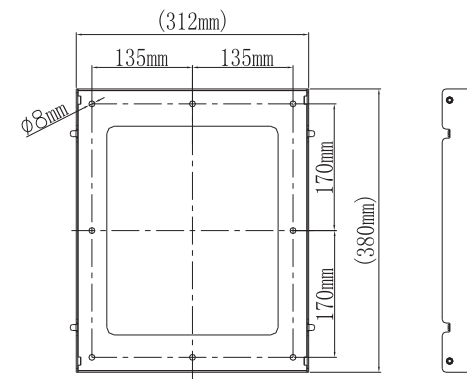

For Replus 4200 / 5000MTLB-US

- Using the mounting frame as a template, drill holes as illustrated in image.

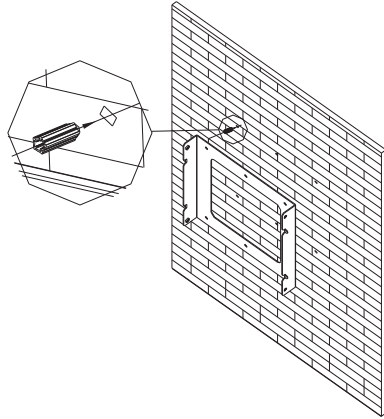

- Fix the mounting frame as the figure shows. Do not make the screws to be flush to the wall. Instead, leave 2 to 4mm exposed.

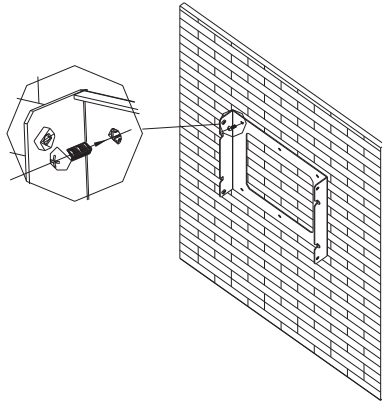

5.4 Fixed the inverter on the wall



WARNING

Falling equipment can cause serious or even fatal injury, never mount the inverter on the bracket unless you are sure that the mounting frame is really firmly mounted on the wall after carefully checking.

- Rise up the inverter a little higher than the bracket. Considered the weight of them. During the process please maintain the balance of the inverter. Hang the inverter on the bracket through the match hooks on bracket.

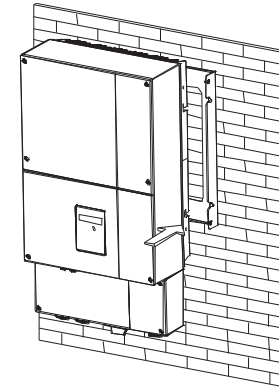

- After confirming the inverter is fixed reliably, fasten four M6 safety-lock sockets head cap screws on the left and right side firmly to prevent the inverter from being lifted off the bracket.

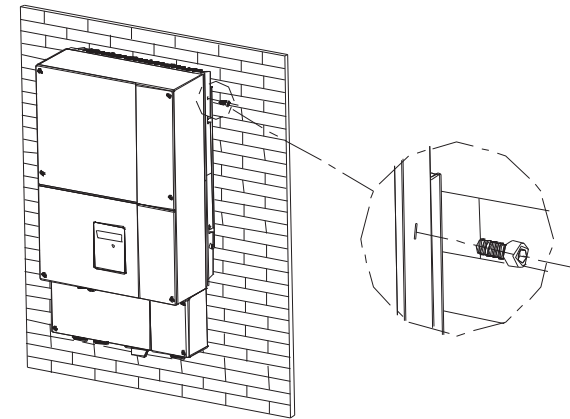

5.5 Check Inverter Installation Status

- Check the upper straps of inverter and ensure it fits on to the bracket.
- Check the secure mounting of the inverter by trying to raise it from the bottom. The inverter should remain firmly attached.
- Choose a strong mounting wall to prevent vibrations while inverter is operating.

5.6 Electrical Connection

5.6.1 Safety



Danger to life due to lethal voltages!
High voltages which may cause electric shocks are present in the conductive parts of the inverter. Prior to performing any work on the inverter, disconnect the inverter on the AC and DC sides



Danger of damage to electronic components due to electrostatic discharge.
Take appropriate ESD precautions when replacing and installing the inverter.



Grounding
Before connecting the power cables, you must connect both ground wire of DC and AC side in wire box first.

5.6.2 System Diagram with Inverter Electrical

Intended Use

The unit converts the DC current generated by the photovoltaic (PV) modules to grid-compliant alternating current and feed-in into the electricity grid. Replus inverters are built according to all required safety rules. Nevertheless, improper use may cause lethal hazards for the operator or third parties, or may result in damage to the units and other property.

- This unit or system is provided with fixed trip limits and shall not be aggregated above 30 kW on a single Point of Common Connection.
 - PV Panel: Provide DC power to inverter.
 - Converts DC (Direct Current) power from PV panel to AC (Alternating Current) power.
- Because Inverter is grid-connected, it controls the current amplitude according to the PV Panel power supply. Inverter always tries to convert the maximum power from your PV panel.
- Connection system: This "interface" between Utility and PV-Inverter may consist of electrical breaker, fuse and connecting terminals. To comply with local safety standards and codes, the connection system should be designed and implemented by a qualified technician.
 - Utility: Referred to as "grid" in this manual, is the way your electric power company provides power to your place.

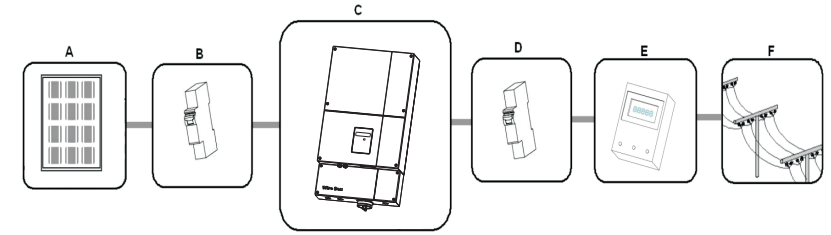

Principle of PV plant system

Position	Description
A	PV modules
B	DC load circuit fuse or breaker
C	Replus Inverter
D	AC load circuit fuse or breaker
E	Energy meter
F	Utility grid

Wire box

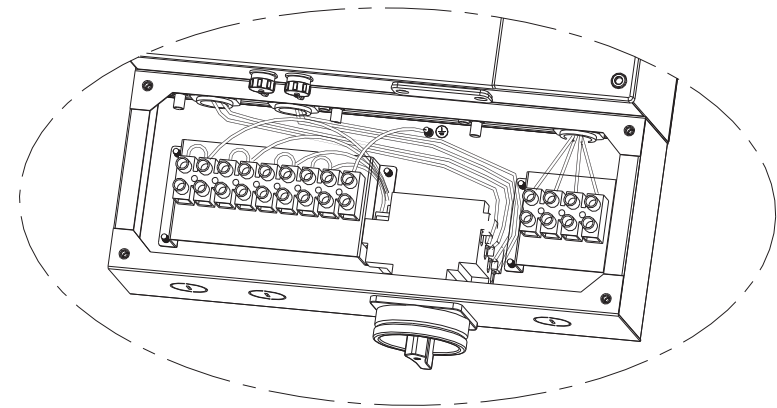

In the wire box, the right side is AC output wire connection terminal, and the left side is PV input wire connection terminal, the middle is DC switch.



WARNING

The separate disconnection unit spec require as follow:
 Voltage: the voltage must not less than the AC grid voltage which you connection.
 Current: the current must not less than 1.2 times of the inverter max output current which defined in the inverter spec.

We suggest the AC separate unit spec as follow:

Model Grid type	Replus 3600MTLB-US	Replus 4200MTLB-US	Replus 5000MTLB-US
@208Vac	25A/400Vac	30A/400Vac	30A/400Vac
@240Vac	25A/400Vac	25A/400Vac	30A/400Vac
@277Vac	20A/400Vac	25A/400Vac	25A/400Vac

> **Wiring Step :**

1. Open the AC separate unit between the inverter and utility and the DC switch on the inverter.
2. Open the wire box cover and the knock-out hole.

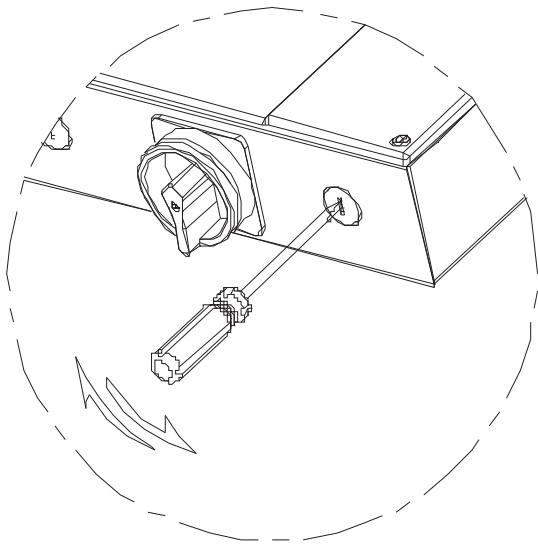

3. installation rubber pipe into the knock-out hole and pull the pipe nut slightly, feed the cables through the pipe into the wire box till the terminal

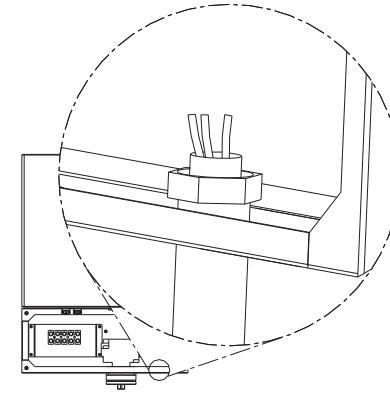

4. The AC side terminal is clear, Connect cables into relevant terminals as the figure 5.6.3

> **Cable requirements**

Product Model	Area(mm ²)	AWG No.
Replus 3600MTLB-US	5.26~9.0	8~10
Replus 4200MTLB-US	5.26~9.0	8~10
Replus 5000MTLB-US	5.26~9.0	8~10



NOTICE

The cables length should not exceed 50 m, the resister of the cable will consume inverter output power , finally resistance the inverter efficiency .



Use only solid or stranded wire but not fine stranded wire.

- Use cables with high ambient temperatures.
- Use cables with a large cross-section .



Code	Name	Detail
A	Conductor cross-section	See the Conductor cross section in the flowing chart
B	Stripping insulation	12mm

5.6.3 Connecting to the grid (AC utility)

Grid standard

Before wiring the inverter, the installer needs to determine the grid configuration that the inverter will be connected to. The Replus inverter is default set for utility interconnection with 240Vac Split Phase from factory. However, you can choose the Net MODEL through the LCD to set the inverter to be fitted the commonly used utility configuration types shown in the figure 5.6.3.

Based on the local grid standards, it is possible to select different connection types. The available configurations are shown in the following table:

GRID STANDARD	L1 • N L2				L1 L3 L2				L1 L2 L3				L1 N L3			
	240Vac Split-phase				208Vac 3phase- Δ				240Vac 3phase- Δ				277 3phase-Y			
AC terminal pin (from left to right)	1	2	3	4	1	2	3	4	1	2	3	4	1	2	3	4
wiring to terminal pin	L1	L2	N	PE	L1	L2	-	PE	L1	L2	-	PE	L1	N	-	PE
NET MODEL	NET MODEL:1 (Default)				NET MODEL:2 (Option)				NET MODEL:3 (Option)				NET MODEL:4 (Option)			

figure 5.6.3

NOTE: in the inverter wire box, AC terminal pin is written as L1, L2, N and PE, not the pin number, that just for the default net model.

if you connect to other net model, you must connect the wire to the terminal pin number exactly as above.

If several Replus inverter are installed in a three-phase AC grid, it is recommended to distribute the inverters between the phases in order to reduce the power unbalances between the phases. Always refer to the local standards.



si plusieurs Replus inverter sont installés sur un réseau électrique à courant alternatif à trois phases. Il est recommandé de distribuer les onduleurs entre les phases pour réduire les déséquilibres de puissance entre les phases. Toujours vous référer aux normes locales.

Connection of the AC cable

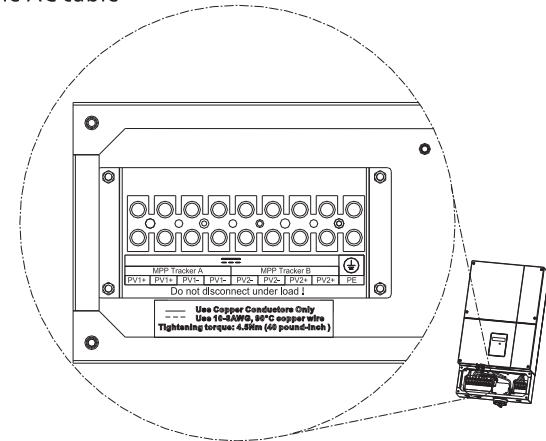

Output connection terminal

Make sure the grid (AC utility) configuration types. If your grid standard is not the factory default type, don't worry, you just need to wire the local AC grid according to figure 5.6.3, after wiring both DC input and AC output, you can use the LCD to choose the NET model to make the inverter suit the local grid type in chapter 6.2 "Setting the LCD display".

You must install a separate AC circuit-breaker or other load disconnection unit between the inverter and utility, in order to ensure that the inverter can be safely disconnected under load.

5.6.4 Connect to PV Panel (DC input)

 DANGER	<p>Risk of electric shock and fire, use only with PV modules, and with a maximum system voltage of 600Vdc.</p>
	<p>Electric shock hazard, the DC conductors of this photovoltaic system are normally ungrounded but will become intermittently grounded without indication when the inverter measures the PV array isolation.</p> <p>Because of the transformer less design, the DC positive pole and DC negative pole of PV arrays are not permitted to be grounded.</p>
	<p>Do not disconnect the DC connectors under load!</p>

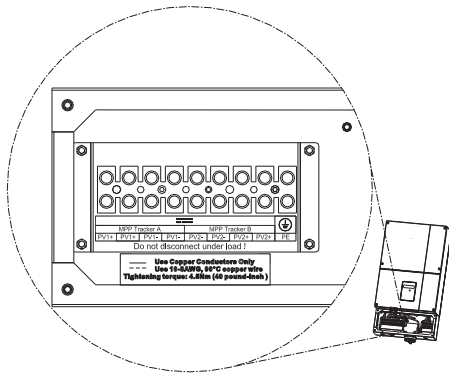

Input connection terminal

There are two MPP trackers of Replus MTLB-US series, so you can connect two independent MPP channels.

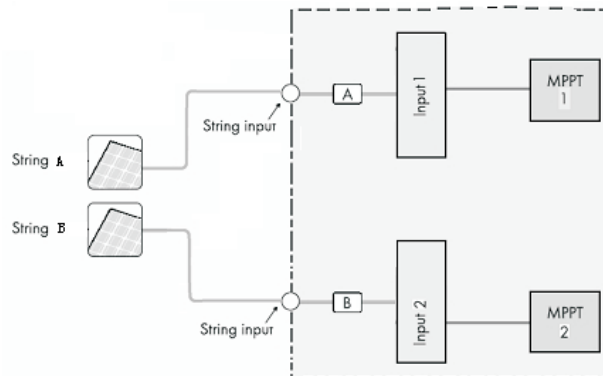

> Suggestions for the PV modules of the connected strings:

- Same type
- Same quantity of PV modules connected in series

> Wiring inverter in parallel

The inverter can be connected in parallel in order to obtain more power, each inverter shall connect to its own PV array, cannot connect a single PV array to more than one inverter. That will cause the inverter to work abnormally, the worst condition inverter will be damaged.

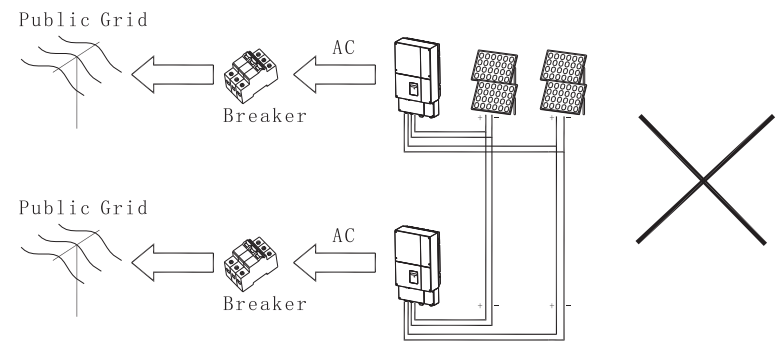
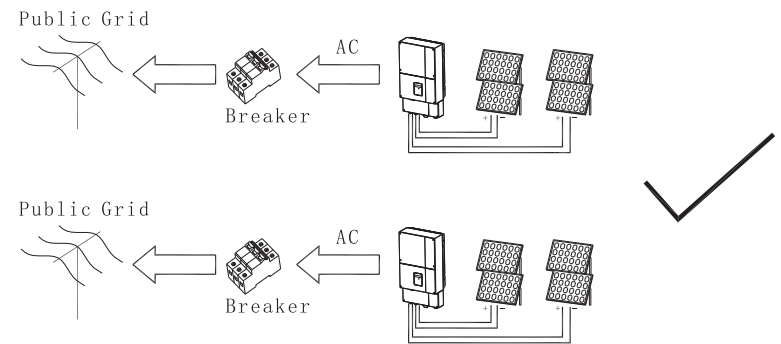

- Under any condition! Make sure the maximum open circuit voltage (Voc) of each PV string is less than 600Vdc.
 - Do not connect strings with an open circuit voltage greater than the Max. input voltage of the inverter. If the strings voltage exceeds the Max. input voltage of the inverter, it can be destroyed due to overvoltage. All warranty claims become void.
 - Check the design of the PV plant. The Max. open circuit voltage, which can occur at solar panels ambient temperature of -10°C, must not exceed the Max. input voltage of the inverter.
- Before connecting PV panels to DC terminals, please make sure the polarity is correct. Incorrect polarity connection could permanently damage the unit. Check short-circuit current of the PV string. The total short-circuit current of the PV string should be less than the inverter's maximum DC current.
- Connect the positive and negative terminals from the PV panel to positive (+) terminals and negative (-) terminals on the PV-Inverter. Each DC terminal on Inverter can withstand 15Adc for 5000MTLB-US and 4200MTLB-US, 12Adc for 3600MTLB-US.
- For instance, if the positive pole of a string is connected at MPP tracker A and the string's negative pole at MPP tracker B, this is called a mixed connection, the inverter no longer fulfils the requirements of the EMC Directive. Only connect strings at one input zone and never mix the input zones A and B!
- High voltages exist when the PV panel is exposed to the sun. To reduce risk of electric shock, avoid touching live components and treat connection terminals carefully
- Wiring step:
 1. Open the independent DC separate unit ,the DC switch on the Replus MTLB-US inverter and the AC separate unit.
 2. Open the left hand side knock-out hole.

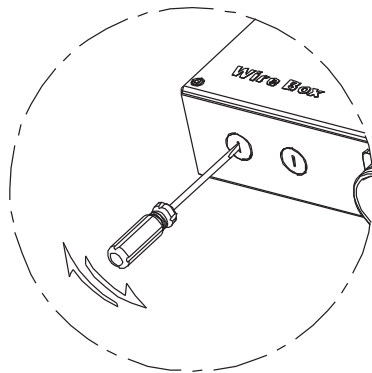

3.installation rubber pipe into the knock-out hole and pull the pipe nut slightly, feed the cables through the pipe into the wire box till the terminal.

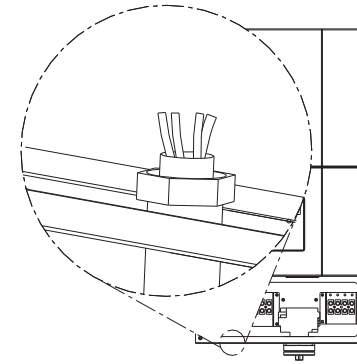

4.connect the PV cables to the terminal correct.

➤ Cable requirements

Product Model	Area(mm ²)	AWG No.
Replus 3600MTLB-US	5.26~9.0	8~10
Replus 4200MTLB-US	5.26~9.0	8~10
Replus 5000MTLB-US	5.26~9.0	8~10

5.7 Commissioning Checking

- Cover the wire box.
- Close the DC separate unit and the DC switch on the inverter.
- When the PV panels are connected and PV voltage is greater than 100 Vdc but the AC grid is not yet connected, the message on the LCD display produce the following messages in order: "Replus Inverter"-> "Waiting" -> "No AC connection". The display repeats "No AC connection" and the LED will be red.
- Setting grid model choice. See the chapter 6.2 "Setting the LCD display".
- Close the AC separate unit between inverter and grid. The normal operating sequence begins.
- Under normal operating conditions the LCD displays "Power: xxxx.xW". That is the power fed to the grid. The LED turns green.
- This completes the check.

6 LCD display

Glossary

AC	Abbreviation for "Alternating Current".
DC	Abbreviation for "Direct Current".
Energy	Energy is measured in Wh (watt hours), kWh (kilowatt hours) or MWh (megawatt hours). The energy is the power calculated over time. If, for example, your inverter operates at a constant power of 20,000 W for half an hour and then at a constant power of 10,000 W for another half an hour, it has fed 15, 000Wh of energy into the power distribution grid within that hour.
Power	Power is measured in W (watts), kW (kilowatts) or MW (megawatts). Power is an instantaneous value. It displays the power your inverter is currently feeding into the power distribution grid.
Power rate	Power rate is the ratio of current power feeding into the power distribution grid and the maximum power of the inverter that can feed into the power distribution grid.
Power Factor	Power factor is the ratio of true power or watts to apparent power or volt amps. They are identical only when current and voltage are in phase than the power factor is 1.0. The power in an ac circuit is very seldom equal to the direct product of the volts and amperes. In order to find the power of a single phase ac circuit the product of volts and amperes must be multiplied by the power factor.
PV	Abbreviation for photovoltaics.

6.1 Display and messages

6.1.1 LCD display

Starting-up display sequence, Once the PV power is sufficient, Inverter displays information as shown in the flow chart as follow:

Module: xxxxxx
 Ser No: xxxxxxxxxx
 FW Version: x.x.x
 Connect in: xxS
 Connect : OK
 Power: xxxx.xW

6.1.2 LCD control

- > The LCD display's backlight automatically turns off after 30 seconds to save the power. The display on the inverter can be control by Knock on the front of it.

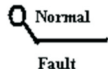
Symbol	Description	Explanation
	Tap symbol	Indicates display operation
	Inverter status symbol	Indicates inverter operation status

- > The first line will show some status of the inverter, there are 5 status listed in below table.

The First Line Of LCD		
STATE	DISPLAY CONTENT	REMARK
Wait State	Standby Waiting Connect in xx S Reconnect in xx S	PV voltage low Initial waiting System checking System checking
Inverter State	Connect OK Power: xxxx.x W	Connect to Grid Inverter watt at working
Fault State	Error: xxx	System Fault
Program State	Programming	Update Software

While Replus inverter is working, the first line will normally show Power status:

Power : 2016.4w
AC:120/120 F:60HZ

> The Second line can change by knock on .

The Second Line Of LCD		
Cycle display	Display time/S	Remark
Power : 2013.4w model: P7U1M2S4	2	The inverter model
Power : 2016.8w FW Version: U.1.2	2	The software version
Power : 2012.8w SerNO:DK00000000	2	The Serial Number

Power : 2019.6w Etoday: 7.1kwh	4	The energy today
Power : 2017.0w Eall: 90kwh	4	The energy all
Power : 2017.0w Ppv:786/1234.6w	4	PV input watt
Power : 2013.4w PV: 310/313 B: 370V	4	The PV and Bus Voltage
Power : 2016.2w AC: 120/120 F: 60.0Hz	4	The grid system
Power : 2019.5w Set Language	4	Set Language
Power : 2008.2w Set LCD Contrast	4	Set LCD Contrast
Power : 2019.5w COM Address: Move	4	Set Communications Address
Power : 2016.2w Net Model: 1	4	Set Net Model

When inverter started to connect to grid, the following message will appear on LCD screen.

Power : 2009.6w
Etoday: 7.1kwh

6.2 Setting the LCD display

The inverter can support three kinds of knock: single knock, double knock. Each kind of knock has different function. Refer to specified definition in Table below :

Knock type	Definition
Single knock	Key Down
Double knock	Key SET

Before light the background, the types of knock functions are the same: just light the background.

That the background light will automatically off if there is no knock detected in 10 seconds.

Sound control can define the display language, luminance of the display, and utility model choice. When the LCD is dark, Knock and double knock make it becomes bright. Knock to make it display next information or change the set situation. Double knock make the display stand for 30 second, enter to setting the menu.

➤ Setting language

Knock to make the display bright→ knock to "set language"→double knock to enter "language: English"→knock to select the language you need and wait until the display become dark.

➤ Setting luminance of the display

Knock to make the display bright →knock to "set LCD contrast"→double knock to enter "LCD contrast 2"→knock to select the luminance you need and wait until the display become dark.

➤ Setting communication address

Knock to make the display bright-->knock to "COM Address: xx" -->double knock to change the Address model-->clock to set address.

➤ Setting grid model choice

This function is disable when the inverter work in the normal state, you much turn off the AC separate unit, and the inverter LCD will display a error "NO AC Connection" , LED turn red ,then this model choice function is enable.

Knock to make the display bright →knock to "Net Model: xx" →double knock to enter "Net Model: xx"→knock to select the grid model .need to wait for 10S till the CPU restart.

Then check the "NET Model" in LCD display again.

Turn on the AC separate unit, inverter begin to work.

Power : 2016.2w
Net Model: 1

Power : 2016.2w
Net Model: 2

Power : 2016.2w
Net Model: 3

Power : 2016.2w
Net Model: 4

7 Communications

7.1 Monitoring Products

7.1.1 Replus Net

Replus NET is a PC software that communicate with inverter to analyze the inverter working state. It is convenient for you to know the inverter's real-time working state and the history work information.

➤ Specification:

Communicate with inverter by RS232 and Bluetooth.

Construct net with inverter, GRO monitor and Replus NET by RS232, Bluetooth and Internet.

Two Interfaces: Multi Inverter Interface and Wave Data Interface.

In Multi Inverter Interface: See at most 4 inverters working data at the same time, you can select your own compare inverters and parameters.

In Wave Data Interface: Query the inverter real time and history power wave,work data and error information.

Multi languages: English, French, German, Spanish and etc.

Support OS: WinXP/ Vista/win7/2000/2003.

7.1.2 Replus Vision

Replus Vision, which consists of a power monitor and a number of transmitters, can achieve 1 to 6 monitoring modes. The transmitters transmit the power data collected from a photovoltaic inverter to the monitor and display the data onto the monitor screen, as along as data of generated energy, the gross generated energy and the generation income obtained from the above-mentioned data through some simple calculations. We can also see AC voltage, two-way PV voltage, indoor temperature, date and time, as well as CO2 emissions.

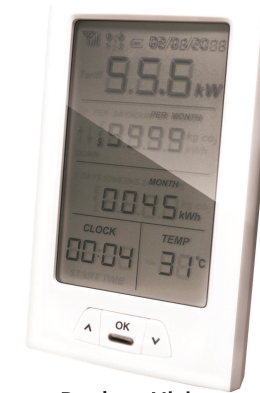

Replus Vision

7.1.3 Replus Pano

Replus Pano have a large touch screen, customers can browse data or set communication parameters, inverter parameters by touching easily. It is designed for solar power plant remote monitoring. While supporting both wired and wireless communication, ReplusWebbox can simultaneously monitor, record and analyze inverter operating parameters real time with a maximum quantity of 50. Monitored data also can be sent to Replus Server.



Replus Pano

7.1.4 Replus Webbox

Replus WebBox is specially designed for solar power plant remote monitoring. While supporting both wired and wireless communication, Replus WebBox can simultaneously monitor, record and analyze inverter operating parameters real time with a maximum quantity of 50. Monitored data can be sent to ReplusServer.



Replus WebBox

7.1.5 Replus Server

Replus Server is a remote data server, it is based on B/S structure. It can receive monitoring data from Replus Webbox or Replus Pano, and publish monitored data to LAN or WAN. User can easily access data browse interface via an Internet Explorer.

7.2 Monitoring System

The inverter provides RS485 interface and RS232 interface to communicate with remote PC or logger. User can monitor the inverter's state via the following types of communication systems.

> Through RS485 interface-Data logger

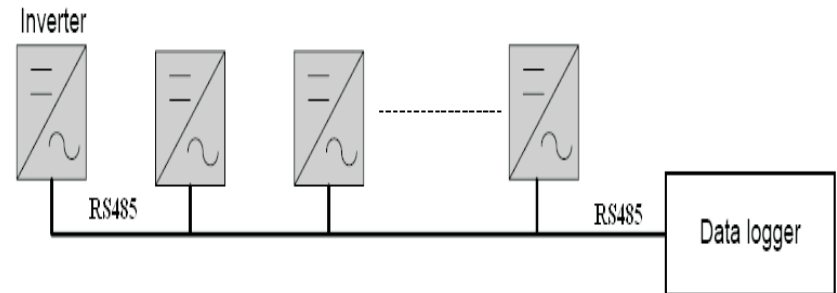

> Through RS485 interface-Data logger+ PC

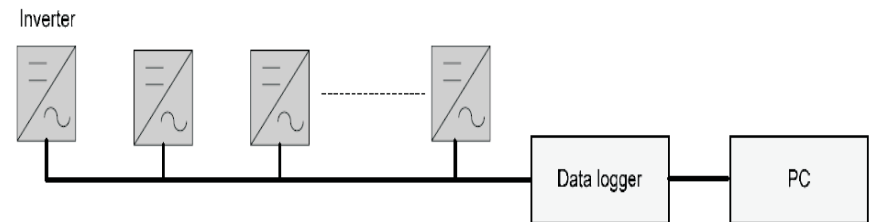

> Through RS485 interface-RS485-232 converter+ PC

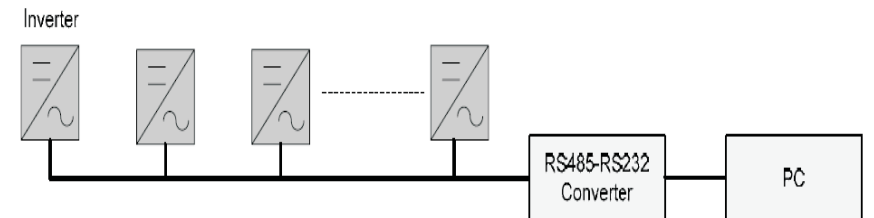

7.3 RS485 cable connection

1. Unscrew the plastic connector.

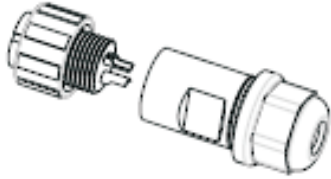

2. Make the RS485 cable go through the connector.

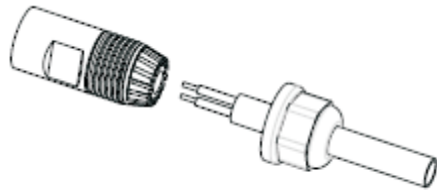

3. Put two heat shrink tubes onto the front head of RS485 cable.

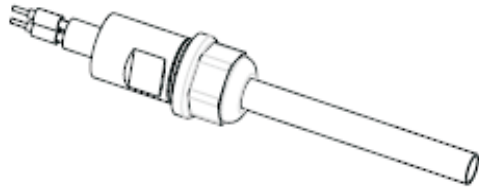

4. Insert the two metal head into relevant small cupreous hole, and fasten the connection by soldering.

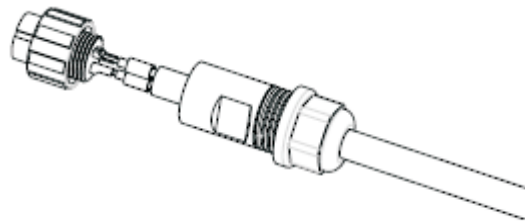

5. Make the heat shrink tubes wrap the joint.

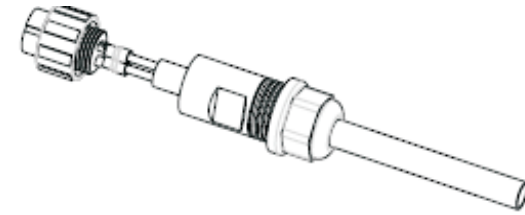

6. Assemble the connector.

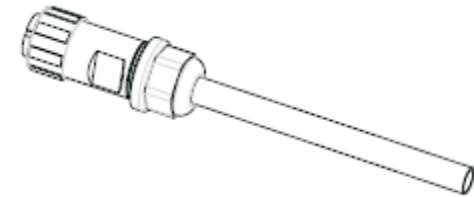

7. Connect the RS485 connector onto the inverter. Make sure the connection matched ('1' to '1', '2' to '2').

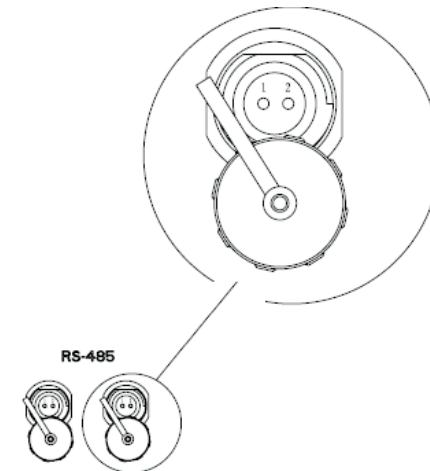

7.4 Using Replus tool to set the information of the inverter

About the software of Replus tool and the usage of it please download from the web:
www.renesola.com

8 Start-Up and shut down the inverter

8.1 Start-Up the inverter

1. Connect the AC circuit breaker
2. Turn on the DC switch, and the inverter will start automatically when the input voltage is higher than 150V.

8.2 Disconnecting the Inverter

1. Disconnect the AC circuit breaker and prevent it from being reactivated.
2. Turn off the dc switch.
3. Check the inverter operating status.
4. Waiting until LED,LCD display have gone out, the inverter is shut down.

9 Maintenance and Cleaning

9.1 Checking Heat Dissipation

If the inverter regularly reduces its output power due to high temperature, please improve the heat dissipation condition. Maybe you need to clean the heat sink.

9.2 Cleaning the Inverter

If the inverter is dirty, shut down the inverter, then clean the enclosure lid, the display, and the LEDs using only a wet cloth. Do not use any cleaning agents (e.g. solvents or abrasives).

9.3 Checking the DC switch

Check for externally visible damage and discoloration of the DC disconnect and the cables at regular intervals. If there is any visible damage to the DC disconnect, or visible discoloration or damage to the cables, contact the installer.



WARNING

Once a year, turn the rotary switch of the DC switch from the On position to the Off position 5 times in succession. This cleans the contacts of the rotary switch and prolongs the electrical endurance of the DC Disconnect.

Decommissioning 10

10.1 Dismantling the Inverter

1. Disconnect the inverter as described in chapter 10.
2. Remove all connection cables from the inverter.



DANGER

Danger of burn injuries due to hot enclosure parts!
Wait 20 minutes before disassembling until the housing has cooled down.

3. Screw off all projecting cable glands.
4. Lift the inverter off the bracket and unscrew the bracket screws.

10.2 Packing the Inverter

If possible, always pack the inverter in its original carton and secure it with tension belts. If it is no longer available, you can also use an equivalent carton. The box must be capable of being closed completely and made to support both the weight and the size of the inverter.

10.3 Storing the Inverter

Store the inverter in a dry place where ambient temperatures are always between -25°C and +60°C.

10.4 Disposing of the Inverter



Do not dispose of faulty inverters or accessories together with household waste. Please accordance with the disposal regulations for electronic waste which apply at the installation site at that time. Ensure that the old unit and, where applicable, any accessories are disposed of in a proper manner

11 Trouble shooting

Sometimes, the PV inverter does not work normally, we recommend the following solutions for common troubleshooting. The following table can help the technician to understand the problem and take action.

Error message	Description	Suggestion
No AC Connection	No utility grid connected or utility grid power failure.	1.Check AC wiring, especially the ground wire 2.Contact Renesola
AC V Outrange	Utility grid voltage is out of permissible range.	1.Check grid typ and voltage. 2.If the error message still exists despite the grid voltage being within the tolerable range, contact Renesola
AC F Outrange	Utility grid frequency out of permissible range.	1.Check grid frequency. 2.If the error message is displayed despite the grid frequency being within the tolerable range, contact Renesola
Over Temperature	Temperature outrange	1.check the inverter operation state 2.If the error message is displayed still,please contact Renesola
PV Isolation Low	Insulation problem	1.Check if panel enclosure ground properly. 2.Check if inverter ground properly. 3.Check if the DC breaker gets wet. 4.If the error message is displayed despite the above checking passed, contact Renesola.
Output High DCI	Output current DC offset too high	1.Restart inverter. 2.If error message still exists, contact Renesola.
Residual I High	Leakage current too high	1.Restart inverter. 2.If error message still exists, contact Renesola.
PV Voltage High	The DC input voltage is exceeding the maximum tolerable value.	Disconnect the DC switch immediately.

Error: 100	2.5V reference voltage fault	1.Restart inverter 2.If error message still exists, contact Renesola.
Error: 101	Communication fault Slave processor can't receive data from Master processor.	1.Restart inverter 2.If error message still exists, contact Renesola.
Error: 102	Consistent fault. Data received by Master and Slave processor are different. The reason can be utility grid voltage or frequency change frequently.	1.Restart inverter. 2.If error message appears frequently or error message still exists after replacement, check utility grid. if you require help, contact Growatt. 3.If error message still exists, contact Renesola.
Error: 116	EEPROM fault	Contact Renesola.
Error: 117	Relay fault	Contact Renesola.
Error: 118	Init model fault	Contact Renesola.
Error: 119	GFCI Device Damage	Contact Renesola.
Error: 120	HCT fault	Contact Renesola.
Error: 121	Communication fault. Master processor can't receive data from Slave processor.	1.Restart the inverter 2.If error message still exists, contact Renesola.
Error: 122	Bus voltage fault	Contact Renesola.

12 Operation Modes

12.1 Normal Mode

In this mode, the inverter works normally and LED turns green.

1. Whenever the DC voltage is higher than 150Vdc, inverter converts power to grid as generated by the PV panels;
2. Whenever the DC voltage is lower than 150Vdc, the inverter will work in waiting state and attempt to connect the grid. In waiting state the inverter consumes just enough power generated by the PV panel to monitor the internal system status;



The inverter starts up automatically when the DC power from the PV panel is sufficient.

12.2 Fault Mode

The internal intelligent controller can continuously monitor and adjust the system status. If inverter finds any unexpected conditions such as system fault and inverter fault, the fault information will be displayed on the LCD. In fault mode the LED turns red.



Detailed fault information refers to 13. Trouble shooting.

12.3 Shutdown Mode

Inverters automatically stop running during periods of little or no sunlight. In shutdown mode the inverters take no power from the grid and panel, and the LCD and LED turns off.



If the PV string DC voltage is too low, the inverter will also turn to Shutdown Mode.

De-rating Operation 13

Temperature

The inverter will monitor the temperature of the heat-sink. Once the temperature exceeds 75°C (167°F), the system will reduce the output power until the temperature drops under the critical value. The inverter will shut down the power output to the grid if the temperature reaches 85°C (185°F). If this occasion happens often, it is necessary to check whether the inverter is mounted at an appropriate place with good ventilation and not directly exposure to the sunshine.

Manufacturer Warranty 14

Please refer to the warranty card.

15 Technical Data

Specifications	Replus 3600MTLB-US	Replus 4200MTLB-US	Replus 5000MTLB-US
Input data			
Max. DC power	3800W	4400W	5200W
Max. DC voltage	600V	600V	600V
Start voltage	150V	150V	150V
DC nominal voltage	360V	360V	360V
PV voltage range	100V-600V	100V-600V	100V-600V
MPP voltage range	120V-550V	120V-550V	120V-550V
Number of independent MPP trackers/strings per MPP tracker	2/2	2/2	2/2
Max. input current of the MPP tracker	12A	15A	15A
Output data			
Nominal AC output power	3600W	4200W	4600W
Max. output current	18A/17.1A/14.8A	21A/20A/17.2A	22A/23.7A/20.5A
AC nominal voltage; range	Default:240V single phase optional:208,240or277 single phase 183-228@208V 211-264V@240V 244-305@277V		
AC grid frequency; range	60Hz;59.3-60.5Hz	60Hz;59.3-60.5Hz	60Hz;59.3-60.5Hz
Phase shift (cos φ)	1	1	1
THDI	<3%	<3%	<3%
AC connection	Single phase	Single phase	Single phase

Efficiency			
Max. efficiency	98%	98%	98%
CEC efficiency	97%	97%	97%
MPPT efficiency	99.5%	99.5%	99.5%

Protection devices			
DC reverse polarity protection	yes	yes	yes
DC switch rating for each MPPT	yes	yes	yes
Output Over current protection	yes	yes	yes
Output Overvoltage Protection-varistor	yes	yes	yes
Ground fault monitoring	yes	yes	yes
Grid monitoring	yes	yes	yes
Integrated all - pole sensitive leakage current monitoring unit	yes	yes	yes

General Data			
Dimensions (W / H / D) in mm	360/650/188	360/650/188	360/650/188
Weight	24KG	26KG	26KG
Operating temperature range	-25...+60°C (-13...+ 140°F) with derating above 45°C (113°F)	-25...+60°C (-13...+ 140°F) with derating above 45°C (113°F)	-25...+60°C (-13...+ 140°F) with derating above 45°C (113°F)
Noise emission (typical)	≤ 25 dB(A)	≤ 25 dB(A)	≤ 25 dB(A)
Altitude	Up to 2000m(6560ft) without power derating		

Relative humidity	95%		
Consumption: operating (standby) / night	<5W / < 0.5 W	<5W / < 0.5 W	<5W / < 0.5 W
Topology	transformerless	transformerless	transformerless
Cooling concept	Natural	Natural	Natural
Enclosure	Type 3R	Type 3R	Type 3R

Features

DC connection:	Screw terminal	Screw terminal	Screw terminal
AC connection	Screw terminal	Screw terminal	Screw terminal
display	LCD	LCD	LCD
Interfaces: RS485/RS232/Bluetooth/Rf/Zigbee	yes/yes/opt/opt/opt	yes/yes/opt/opt/opt	yes/yes/opt/opt/opt
Warranty: 10 years / 15 years	yes /opt	yes /opt	yes /opt
Certificates and approvals	UL1741,UL1998 IEEE 1547, CSA C22.2 No.107.1-1,FCC Part15(Class A&B)		

15.2 Efficiency curve

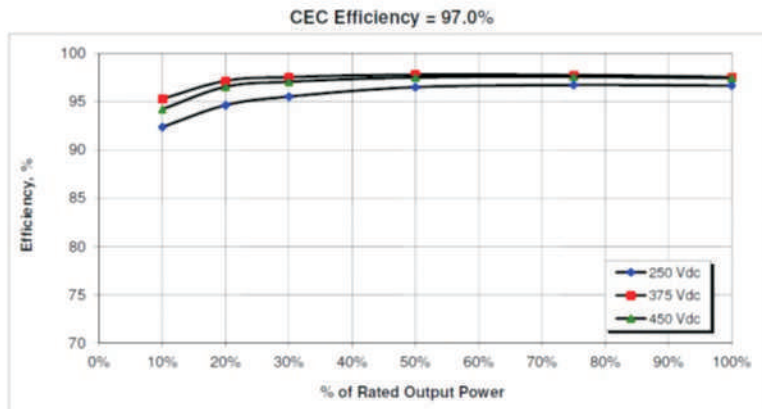

Replus 3600MTLB-US @240Vac

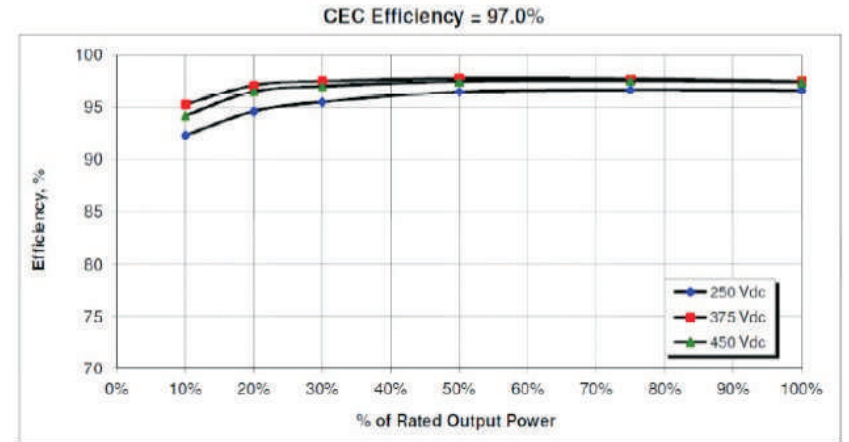

Replus 4200MTLB-US @240Vac

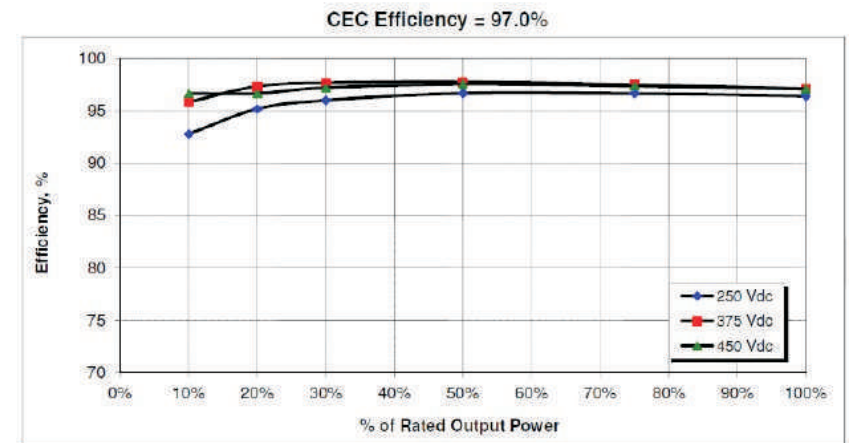

Replus 5000MTLB-US @240Vac

16 Download Address

www.renesola.com

17 Contact

If you have technical problems about our products, contact the Renesola Service line. We need the following information in order to provide you with the necessary assistance:

- Inverter type
- Serial number of the inverter
- Event number or display message of the inverter
- Type and number of PV modules connected
- Optional equipment

Renesola Ltd.

Europe

Add: Renesola Deutschland GmbH, Lyoner Strasse 15, 60529 Frankfurt/M,

Germany

T: +49 69 663 786 9-0

E: europa@renesola.com

U.S.A

Add: 301 Howard St, Suite 850, San Francisco, CA 94105.

T: +1 415 852 7418

E: america@renesola.com

APMEA&China

Add: F-15, Manpo Intl. No.500 WestYan'an Rd, Shanghai, China 200050

T: +86 21 62809180

E: apmea@renesola.com

Australia

Add: 18 Corporate Blvd. Bayswater, VIC 3153, Australia

T: +61 481 251 275

E: australia@renesola.com Web: www.renesola.com

After Service E: stringinverter@renesola.com